

VERTICAL LFP ENERGY STORAGE BATTERY

SPECIALIZED FOR SOLAR PV POWER SYSTEM

RG-LS SERIES

Original
Quality Certification
Made By Raggie



FEATURES

- ※ LiFePo4 cell class A
- ※ Support 15pcs In Parallel
- ※ Vertical Design With Wheels Is Easier To Move
- ※ Compatible With Multiple Inverter Brands
- ※ Ip67 Optional
- ※ 150A BMS for charge/discharge
- ※ 6000 cycle times@DOD80%
- ※ BT/WIFI is optional
- ※ LED/LCD/(touch screen)optional



✓ over 96% self-consumption rate

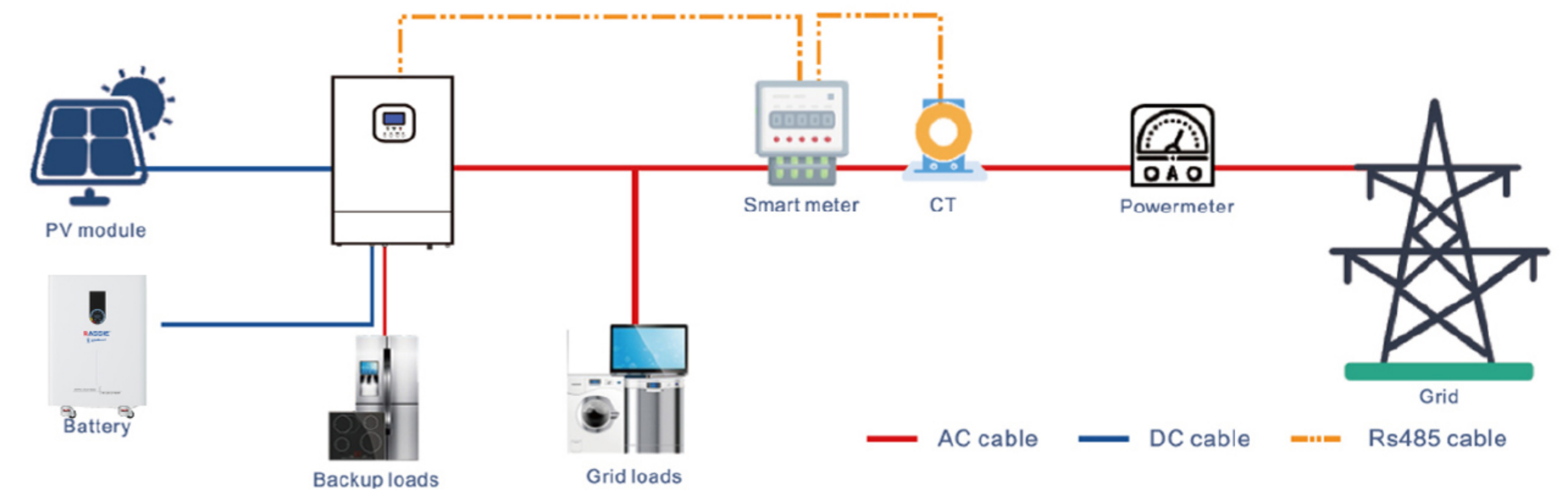

MODEL	RG-LS51.2V-300AH
Standard Voltage	51.2V
Standard Capacity	300Ah
Standard Energy	15.36kWh
Working Voltage	43.2-57.6V
Standard Charge Current	150A
Standard Discharge Current	150A
Suggested DOD	80%
Cycle Life	>6000cycles
IP Rating	IP21(Ip67 optional)
Operating temperature for discharge	-20℃~60℃
Operating temperature for charge	0℃~45℃
Max Parallel	15pcs
Communication	RS232/CAN/RS485(WIFI/BT optional)
Display	LED/LCD/(touch screen)optional
Warranty	5 years
Certificate	UN38.3/MSDS/CE/ROHS/FCC
N.W/unit(kg)	121
G.W/unit(kg)	139
Product Size/unit(mm)	790*530*300
Meas/unit(mm)	870*610*500